

PLATFORM SCALES

type 66 SA 250
type 88 SA 250

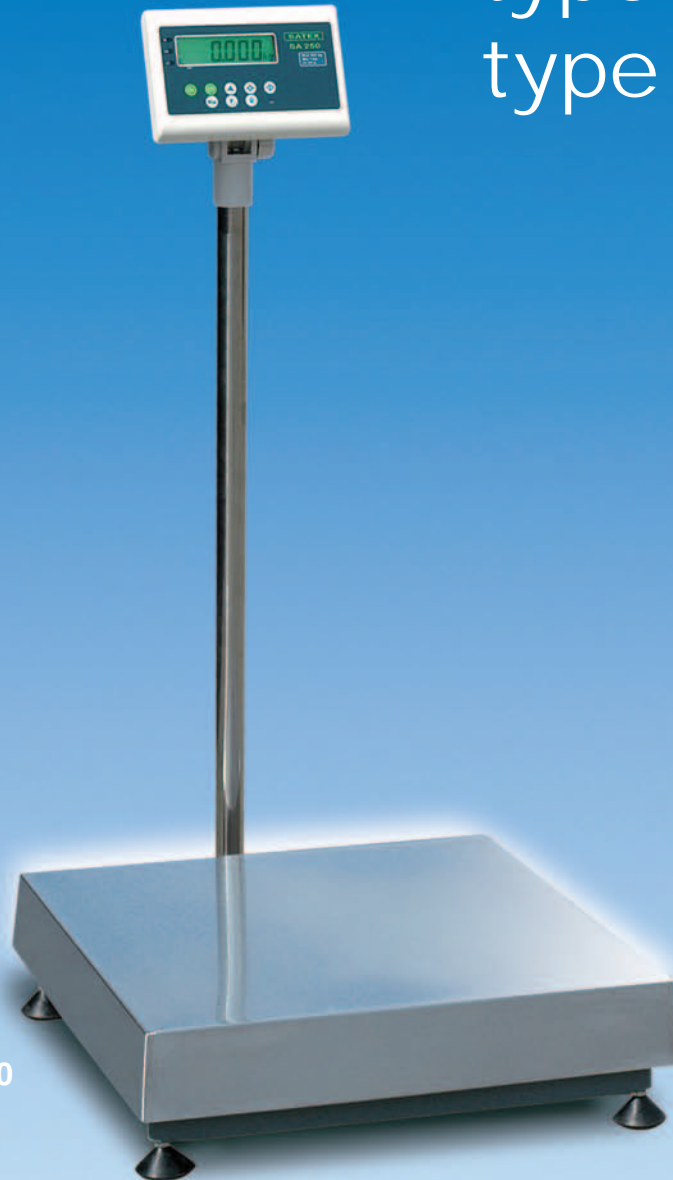

Type 66 SA 250



- ▶ Weighing capacities 60, 150, 300 kg
- ▶ Reading accuracy from 2 gram up
- ▶ CE approval for legal trade
- ▶ Platforms: 60 x 60 cm or 80 x 80 cm
- ▶ RS 232 data output
- ▶ Calibration by the user
- ▶ Built in battery and charger

SATEX

- ▶ **CE approved weighing**
(use for trade)
- ▶ **Piece counting program**
- ▶ **Check weighing program**
- ▶ **High resolution versions**
- ▶ **Data - printer output**
- ▶ **Built in battery and charger**
- ▶ **Pole included**
- ▶ **English manual**



Turnable display

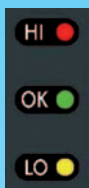

Check weighing with signal LED's



Display front with waterproof keys and back lit display

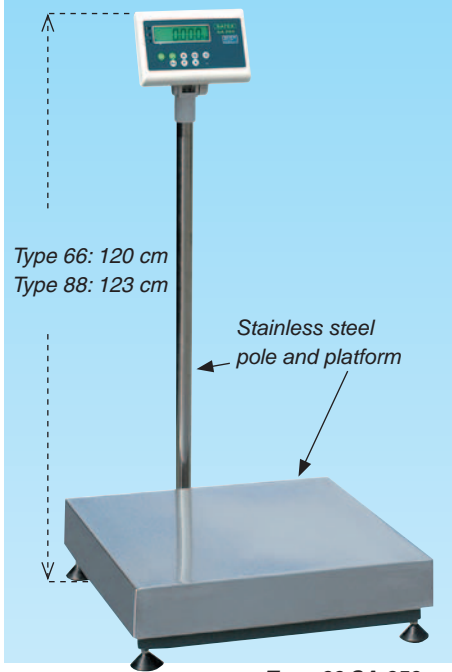

Type 66: 120 cm
Type 88: 123 cm

Type 66 SA 250

READING

Large and bright, 25 mm high LCD display figures with back lighting. Conversion speed 5 Hz. Tare capacity 100% = zero setting over the total weighing range. The automatic zero track keeps the reading at zero with an empty scale. The display unit may be turned over in order to have a good reading angle of the weight reading.

CHECK WEIGHING

Two weight margins, settable via the operating keys as Hi and Low values, for quick weight and dosing controls. Three LED's on the front panel show whether the weight is good, too high or too low. Several audible signals may be connected to the LED signals.

OPERATING KEYS

- on / off
- zero
- check weighing
- toggle: weighing-counting-checkweighing
- piece counting
- tare
- printing

MENU FUNCTIONS (a.o.)

- Auto zero track : off - on
- Display back light : off - on - auto
- Auto off scale : off - selectable time
- Check weighing : off - on
- Weight lock up : key - on
- Print / send data : key - auto - continuous
- Calibration : 1 or 3 points program

EXCITATION

Built in battery and charger for max. 75 hours of stand alone operation. Supplied with 9/230 VAC adaptor included.

USE FOR TRADE

At additional costs the scale may be supplied with a legal EC Certificate and is then allowed for use for trade.

The accuracy remains equal, whether the scale is delivered with or without Certificate. The High Resolution versions are allowed for internal weighing only.

MODELS		TECHNICAL SPECIFICATIONS		
Order nr.	Platform size	Weighing capacity	Scale division	
			Standard	High Resolution
66 SA 250. 60 (HR)	60 x 60 cm	60 kg	20 g	2 g
66 SA 250. 150 (HR)	Free space between platform and display: 89 cm	150 kg	50 g	10 g
66 SA 250. 300 (HR)		300 kg	100 g	20 g
88 SA 250. 60 (HR)	80 x 80 cm	60 kg	50 g	5 g
88 SA 250. 150 (HR)	Free space between platform and display: 87 cm	150 kg	50 g	10 g
88 SA 250. 300 (HR)		300 kg	100 g	20 g
Accuracy	Standard resolution : Meets the legal tolerances for Class III weighing scales according to EN 45501 High resolution version : < 1 scale division.			
Calibration	Adjustment via the menu, using certified weights Class M1 Blocked at legal certified scales.			
Dimensions	Type 66 SA: 62 x 75 x 120 cm (wxdxh), weight 33 kg Type 88 SA: 82 x 95 x 122 cm (wxdxh), weight 46 kg			
Construction	Stainless steel weighplatform, coated steel frames, 4 leveling feet and a spirit level indicator. Turnable indicator in smooth IP 54 housing. HBM loadcell with 6 overload protections.			
Reading	LCD display with 25 mm high figures and soft green back lighting. The back lighting may be switched on or off, or set at automatic switch on if the scale is used (> 0.0 kg)			
Auto off	The scale will be automatically shut down if not used during a selectable time: off, 5, 10, 20, 30 minutes.			
Excitation	Built in battery and charger for 75 hours stand alone operation, (30 hours at continuous display lighting). Charging time 20 hours. Supplied with 9/230 VAC mains adaptor included.			
EC approval	NMI Certificate nr. T 6918, nmax 3000 e.			
Packing	Type 66 SA: 80 x 125 x 35 cm (wxdxh), gross weight 40 kg Type 88 SA: 100 x 145 x 40 cm (wxdxh), gross weight 60 kg			

Vermarktning • CSO Marketing Communicatie • Almere • 2007