



- Double shear load cell
- 3000 divisions O.I.M.L. R60 class C
- Measuring element from stainless steel
- Hermetically sealed, fully welded
- Protected IP 68 (EN 60529)
- Easy installation
- Available in **ATEX**  version (optional)
Zone 0-1-2 (gas) and 20-21-22 (dust)
- Application: Tanks and silos weighing systems with highly linear and low profile requirements
- Dubbele shearbeam krachtopnemer
- Nauwkeurigheid 1:3000 OIML R60
- Meetelement van roestvast staal
- Hermetisch dichtgelast
- Dichtheidsklasse IP 68 (EN 605829)
- Eenvoudige plaatsing d.m.v. montagebok
- Leverbaar in **ATEX**  uitvoering (optie)
zone 0-1-2- (gas) en 20-21-22 (stof)
- Toepassingen:
tank-, menger- en siloweging
met hoge lineariteit en lage bouwhoogte

Model	Nominal capacity Meetbereik E max	Accuracy class Nauwkeurigheid n. OIML	Minimum division Kleinste schaaldeel vmin	Minimum load Min. belasting 0 % E max	Service load Max. belasting 150 % E max	Safe load limit Breuklast 200 % Emax
460 5 t	5 t	3000	0,5 kg	0 kg	7,5 t	10 t
460 10 t	10 t	3000	1 kg	0 kg	15 t	20 t
460 20 t	20 t	3000	2 kg	0 kg	30 t	40 t
460 30 t	30 t	3000	3 kg	0 kg	45 t	60 t
460 50 t	50 t	3000	5 kg	0 kg	75 t	100 t
460 75 t	75 t	3000	7,5 kg	0 kg	112,5 t	150 t
460 100 t	100 t	3000	10 kg	0 kg	150 t	200 t

MODEL 460

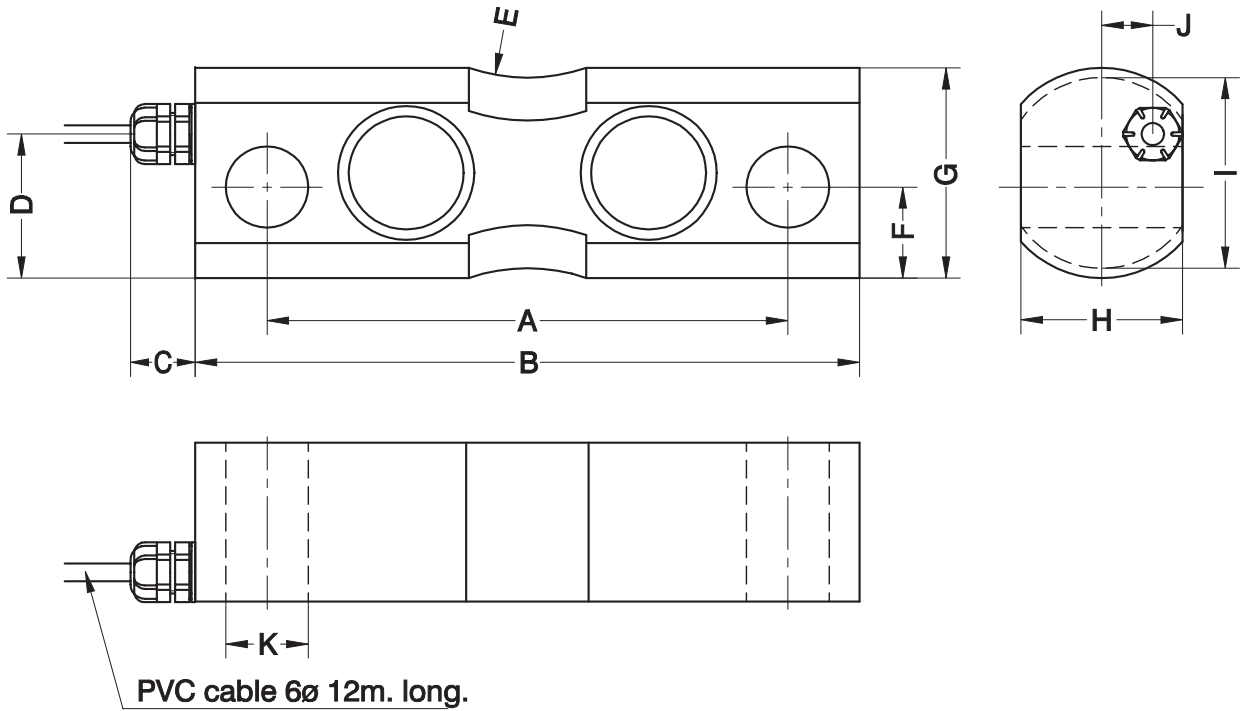

Nominal Load Meetbereik	A	B	C	D	E	F	Gø	H	Iø	J	Kø	Transport weight Transportgewicht
5...20 t	145	185	16	41	r.50	25.7	59.5	45	54	14	23	3,2 kg
30...50 t	220	285	16	48	r.50	29.7	74.5	60	65	22	30	8 kg
75...100 t	260	340	16	66	r.50	37.2	99.5	80	90	32	50	14,3 kg

Dimensions in mm. Afmetingen in mm.

SPECIFICATIONS			TECHNISCHE GEGEVENS
Nominal capacities (Ln)	5-10-20-30 50-75-100	ton	Meetbereiken (E max)
Accuracy class	3000	n. OIML	Nauwkeurigheidsklasse
Minimum dead load	0	% Emax	Minimum voorlast
Service load	150	% Emax	Maximum belasting
Safe load limit	200	% Emax	Breuklast
Total error	< ±0.017	%Sn (1)	Samengestelde fout
Repeatability error	< ±0.015	%Sn	Herhalingsnauwkeurigheid
Temperature effect: on zero	< ±0.01	%Sn/5°K	Temperatuurafwijking: op nul
on sensitivity	< ±0.006	%Sn/5°K	op meetbereik
Creep error (30 minutes)	< ±0.016	%Sn	Kruipfout (30 min.)
Temperature compensation	-10...+40	°C	Temperatuur gecompenseerd
Temperature limits	-30...+70	°C	Temperatuur grenzen
Nominal sensitivity (Sn)	2 ±0.1%	mV/V	Signaalsterkte (Sn)
Nominal input voltage	10	V	Nom. voedingsspanning
Maximum input voltage	15	V	Max. voedingsspanning
Input impedance	800 ±30	Ω	Ingangsweerstand
Output impedance	700 ±3	Ω	Uitgangsweerstand
No load output	±2	%Sn	Nulsignaal tolerantie
Insulation resistance	> 5000	MΩ	Isolatieweerstand
Maximum deflection (at Ln)	0.6-1	mm	Meetweh (bij Emax)

(1) Total error: Non Linearity and Hysteresis / Samengestelde fout = niet lineariteit + hysteresis

ELECTRICAL CONNECTION ELEKTRISCHE AANSLUITING:

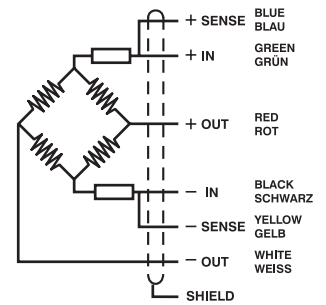

«SENSES»: 2 additional wires to maintain a constant voltage supply at the load cell when used with proper instrumentation. Use specially when long wires and wide temperature range.
SHIELD: Not connected to transducer body.

"SENSE": twee extra aders om de voedingsspanning direct bij de opnemer te meten en terug naar de meetversterker te zenden. De sense ingang van de versterker corrigeert daarmee de weerstandsveranderingen door temperatuurvariaties in de kabel.

MANTEL: is niet aan het huis van de opnemer aangesloten.

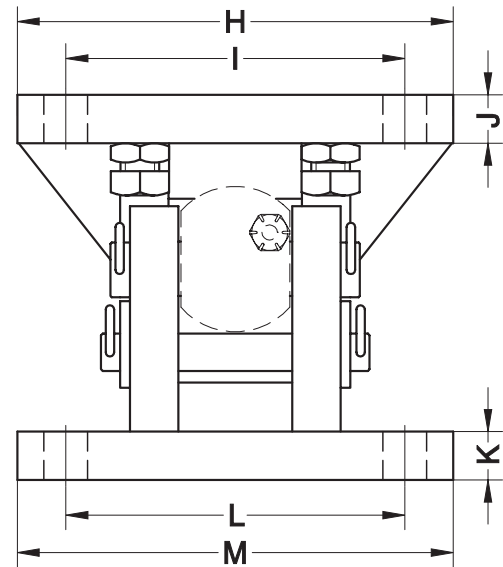
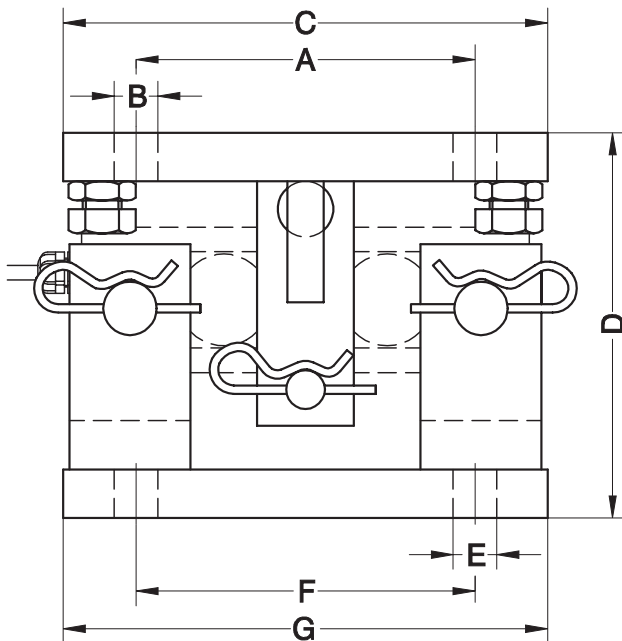
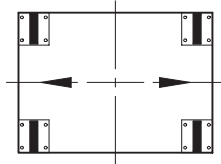
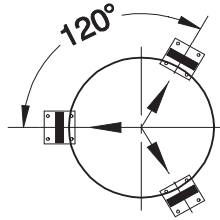
**MOUNTING KIT LIFT-OFF PREVENTION FOR SILO FOR M.460 (5...100t)
MONTAGEBOK MET ANTI-TIL BEVEILIGING VOOR MODEL 460**

Accessory Artikel nr.	Nominal Load Meetbereik	A	B \emptyset	C	D	E \emptyset	F	G	H	I	J	K	L	M	Transport weight Transportgewicht
46901	5...20 t	140	18	200	160	18	140	200	180	140	20	20	140	180	17 kg
46902	30...50 t	175	22	300	200	22	175	300	220	175	25	25	175	220	39 kg
46903	75...100 t	220	26	370	270	26	220	370	300	220	30	30	220	300	82 kg

Acc. Material: Steel alloy zinc-plated	46901	46902	46903	Materiaal : verzinkt staal
Acc. Material: Stainless steel	46901i	46902i	46903i	Materiaal : roestvast staal
Nominal load	5...20 t	30...50t	75...100t	Voor opnemers met meetbereik:
Max. permissible side offset transverse load cell	± 5 mm	± 5 mm	± 10 mm	Max. toegestane dwarsverplaatsing
Maximum permissible lifting force	9000 kg	21000 kg	34000 kg	Max. toegestane verticale trekkracht
Maximum permissible lateral force	4550 kg	8600 kg	12000 kg	Max. toegestane dwarskracht

Dimensions in mm. Afmetingen in mm.